

## Trouble Shooting Guide

Symptom	Check / Remedy
Unit will not turn ON	<ul style="list-style-type: none"> <li>• Is the unit wired into a "working" 120 or 220 (Volt, AC, earth grounded outlet)?</li> <li>• Is the Filter Access Panel Door closed tightly?</li> <li>• Is the fuse blown?</li> </ul>
Unit will still not turn ON	<ul style="list-style-type: none"> <li>• Call HealthWay® Customer Service.</li> </ul>
Unit is ON, but no speed change	<ul style="list-style-type: none"> <li>• Call HealthWay® Customer Service.</li> </ul>
Snap or hissing noise	<ul style="list-style-type: none"> <li>• DFS grid and wires need cleaning. Clean grid and wires with a clean, lint free, dry cloth.</li> </ul>
Bio Monitor Light is OUT	<ul style="list-style-type: none"> <li>• Check to see if there is a broken wire or damage to the DFS grid.</li> <li>• Call HealthWay® Customer Service.</li> </ul>

**WARNING:** To prevent fire or shock hazard, do not expose this unit to rain or moisture.

DFS Commercial Ceiling Air Purification System FLUSH-MOUNT

**HealthWay** *Manual* HW1220-F

*The Global Leader in Air Quality Solutions*



*Commercial Air Filtration*

*Mounts Flush & Out of the Way!  
State-of-the-art technology*

**HealthWay**

HealthWay Products, Inc.

3420 Maple Avenue, Pulaski, NY 13142-0485  
Phone 315.298.2904 • FAX 315.298.6992

Phone: 315.298.2904 • Toll Free: 1.800.843.3860 • FAX: 315.298.6992 • [www.healthway.com](http://www.healthway.com)

## Please Note:

Your HealthWay® 1220-F DFS Advanced Ceiling Air Purification System has been carefully packaged to avoid damage in shipping and storage. **Retain this packaging.**

Please inspect your unit to insure that you receive the product free of any visible signs of damage. If you detect any damage, you should file a claim with the shipping company or carrier within 15 days of receipt.

The HealthWay® 1220-F DFS Advanced Ceiling Purification System is designed for "easy installation" please refer to installation and wiring instructions found in this manual before beginning installation.

To receive maximum benefit from the HealthWay® Model 1220-F DFS Air Cleaner, we recommend replacing the DFS Filter and the Pre-filter every 12 months and the 2-Stage Carbon Filter every 6 months. Please call your local HealthWay distributor to reorder filters.

## Important Safety Precautions:

Please read all instructions before operating your air purifier. Basic precautions should always be observed when using electric appliances to reduce the risk of fire, shock and injury. Do not expose this unit to rain or moisture.

**Observe the following general precautions to insure effective, safe and trouble-free operation of your HealthWay® DFS Air Cleaner.**

**Warning:** This air purifier must be wired into a 120 or 220 Volt, AC earth grounded electrical supply. Do not use this air purifier with a wall outlet adapter. **Do not operate this air purifier with an extension cord.**

1. **Unit must be hard wired when recess mounted** to meet Underwriter's Laboratories Specifications or CE as shown in diagram, Figure 3.
2. **Connect the unit DIRECTLY** into an earth grounded AC electrical POWER per wiring diagram shown on Figure 3.
3. **Mount the Unit** using the proper fastener and support rods as described. Unit must be attached to the building for support. Do not fasten to a false ceiling or plasterboard. See diagram in Figure 1 or 2 for proper mounting instructions.
4. **Do not use this unit in an outdoor environment.** Unit is designed for indoor use only.
5. **Do not place any foreign objects inside the unit** because electric shock and Injury could result.
6. **Do not use the unit if any part is missing** or damaged in any way.
7. **Never operate the air purifier in areas where combustible gases** or vapors are present or any other flammable materials.
8. **Never spray the unit with water or other liquids,** spray the air purifier with liquids or clean the air purifier under running water.
9. **Do not operate this unit with a damaged cord of plug,** or after the unit Malfunctions or has been damaged in any manner. Call HealthWay® Customer Service at 1-315-298-2904 for servicing instructions.
10. **If it is necessary to take unit out of ceiling** for any reason, be sure to wait for the motor to stop spinning to prevent injury.

## Limited Warranty Information (continued)

### Limitations:

HealthWay® shall not be liable for property, incidental, and/or consequential damages of any kind and, unless otherwise prescribed by applicable state law, HealthWay® shall not be liable for personal injury resulting from malfunctions, defects, misuse, improper operation or installation, or alteration of a HealthWay® product or any part thereof. The exclusive remedy for a breach of this Limited Warranty is the repair or replacement of the defective product. In no case, shall liability under any other remedy prescribed by law exceed the purchase price of the product.

### Statutory Rights:

This Limited Warranty, subject to the above exclusions and limitations, gives you specific legal rights in addition to statutory rights you may have under applicable state law. Some states, however, do not permit the limitation or exclusion of incidental or consequential damages, so such limitation may not apply to you. To the extent that any provision of this Limited Warranty is inconsistent with applicable law, such provision shall be deemed void or amended, as necessary, to comply with such law.

### Warranty Claims Procedure:

The validity of a product claim under this Limited Warranty depends upon your following these simple steps. **To make a product claim, please follow steps A-D:**

- A. **Obtain Warranty Claim Number:** Call HealthWay® Customer Service at 1-315-298-2904 to obtain a Warranty Claim Number for your unit.
- B. **Packaging and Shipping:** Carefully pack the product in its original carton with original packaging materials or comparable box and materials to avoid damage in shipping. HealthWay® recommends that you ship the unit by Federal Express – Ground Freight.  
**Unit must be shipped on a skid to prevent damage. ALL OUTBOUND AND RETURN WARRANTY PRODUCT SHIPPING CHARGES MUST BE PREPAID BY YOU.**  

HealthWay® cannot accept freight collect shipments.
- C. **Assemble and Enclose Information:** Enclose the following information in an envelope and tape the envelope to the unit itself:
  - (1) Warranty Claim Number
  - (2) Your name, complete address with zip code, and telephone number
  - (3) Dated sales receipt or dated Proof of Purchase
  - (4) Short specific description of the malfunction
- D. **Ship the Product Prepaid to:**  
Warranty Claim Department  
Warranty Claim Number \_\_\_\_\_  
HealthWay Home Products, Inc.  
3420 Maple Ave.  
Pulaski, NY 13142-0485

**This Shipping Address and the Warranty Claim Number Must, without exception, appear on the outside of the shipping carton.**

## HealthWay® Offers a Limited Warranty on All Commercial Products

- 1) Retain proof of purchase and the original box and packaging materials.
- 2) Mail **Warranty Registration Card** within 10 days of date of original purchase  
OR
- 1) Fax **Warranty Registration Card** within 10 days of date of original purchase.
- 2) To make a product claim, call **1-315-298-2904** to obtain a warranty claim number.

### Product Registration:

HealthWay® makes this Limited Warranty ("Limited Warranty") ONLY to the original retail purchaser who completes the enclosed Warranty Registration Card within ten (10) days of purchase and faxes it to: 1-315-298-6992; or mail to: HealthWay® Home Products, Inc., 3420 Maple Avenue, PO Box 485, Pulaski, New York 13142

### Limited Warranty Information:

This Limited Warranty applies only to the repair or replacement of any manufactured or supplied part of this product which, upon inspection by HealthWay® authorized personnel, proves to have failed in normal use due to defects in material or workmanship. The sole responsibility of HealthWay® under this Limited Warranty is, in its sole discretion, to either repair or replace a duly registered product (or defective part thereof) with the same or a comparable model within a reasonable period of time, subject to the following exclusions, limitations, statutory rights, and warranty claim procedures. This Limited Warranty is exclusive, and HealthWay® expressly disclaims all other or additional warranties, whether written or oral, expressed or implied, including, but not limited to, warranties of merchantability, workmanship, or fitness for a particular purpose.

### Exclusions to the Warranty:

- A. This Limited Warranty does not apply, or is void, as to any product or part damaged by (1) accident, misuse, abuse, or lack of reasonable care or normal maintenance; (2) installation or operation under conditions other than those recommended by HealthWay®; (3) subjecting the product to any but the specified voltage; (4) servicing or disassembly by unauthorized personnel; (5) removing or defacing the serial number; or (6) modifying the original factory-assembled unit in any way.
- B. **THIS LIMITED WARRANTY DOES NOT APPLY TO SHIPPING CHARGES FOR PRODUCT SHIPPED TO OR FROM THE FACTORY OR DESIGNATED SERVICE CENTER IN CONNECTION WITH WARRANTY CLAIMS NOR DOES IT APPLY TO ANY DAMAGES OCCURRING DURING SUCH SHIPMENT.**
- C. This Limited Warranty does not apply to installation, removal, reinstallation, and/or Related expenses. **This Limited Warranty does not apply to replaceable filters.**

## HealthWay COMMERCIAL CEILING AIR PURIFICATION SYSTEM Model HW1220-F DFS

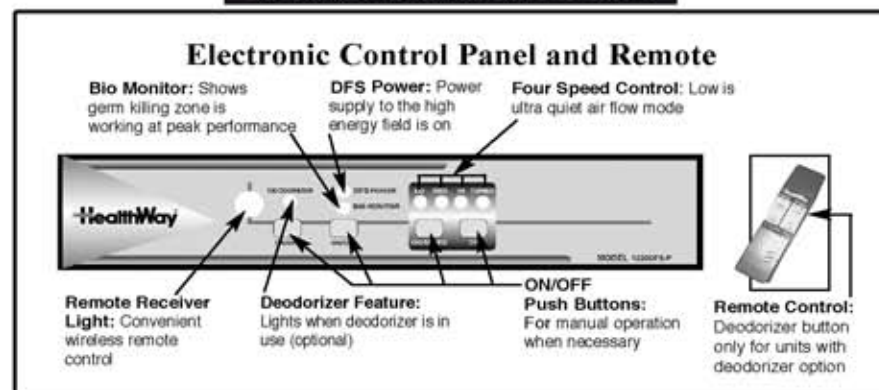

Clean One Large Area -or- Up to Four Areas by Using HW 1220-D Kit

**CAUTION NOTICE!**  
To prevent injury, please wait for motor to stop spinning before changing filters or before taking unit out of the ceiling.

# Commercial 1220 DFS Ceiling Mount Instructions



1. Remove all packing material before pulling out the unit.



2. Place unit on a flat sturdy surface with control panel on bottom as shown.



4. Unscrew the two black thumb screws on top of the unit.



5. Gently pull louver from housing and unHINGE from hinges at bottom of unit. Unplug the component section as shown in Photo 10 also on page 5.



6. After unHINGE front of unit from housing, set front of unit on a stable hard surface for hanging later.

**IMPORTANT: UNIT MUST BE ATTACHED TO BUILDING STRUCTURE**

## Threaded Rods Ceiling Preparation Instructions

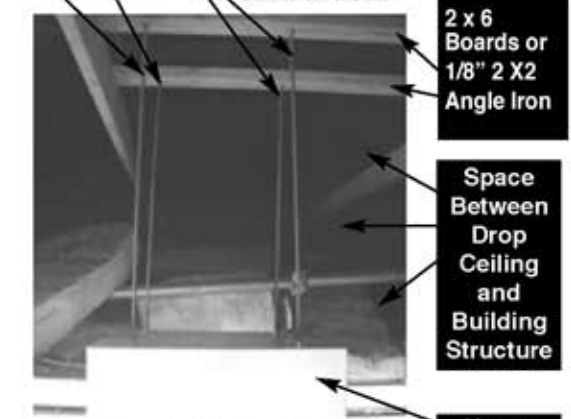

2 x 6 Boards or 1/8" 2 X2 Angle Iron

Space Between Drop Ceiling and Building Structure

Upper Housing of Unit

7. Prepare ceiling for mounting unit. Lift unit housing and attach to threaded steel rods according to Fig. 1 on page 4. Hardwire by following Fig. 3 on page 5.



8. Above photo shows HealthWay 1220 Commercial Ceiling Unit housing in place after proper installation.



Cleans up to 4 rooms using HealthWay's HW 1220-D Kit. Kit includes front replacement panel and 4 duct collars (flexible hose not included).

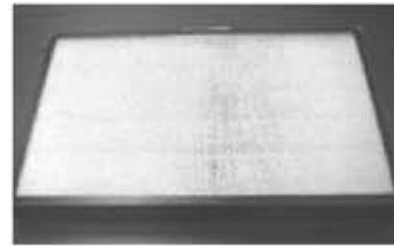

**DFS Filter**  
4010

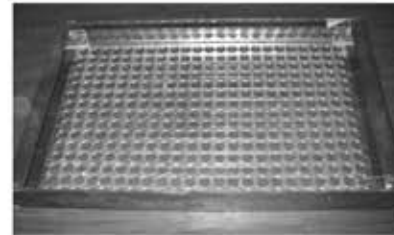

**DFS Grid**  
4016



**2 Stage Carbon Filter**  
4004A

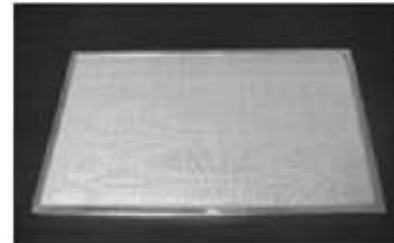

**2 Stage Pre-filter**  
4003



**PCO BULB**  
2028A



**Remote**  
(Deodorizer is optional)  
4021 (with deodorizer)  
4020 (without deodorizer)



**1220 Duct Kit**

# HealthWay COMMERCIAL CEILING Air Purification System MODEL 1220-DFS

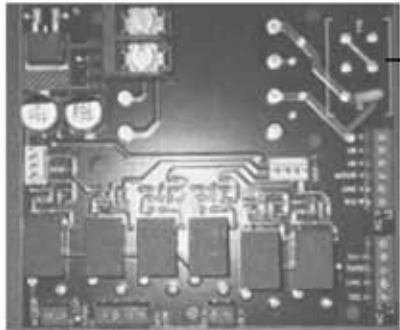

**Relay Board**  
2022B

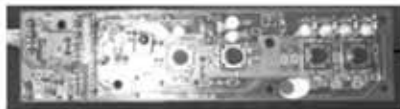

**Control Panel**  
2018&



**Power Supply**  
2010 (110v)  
2010-A (220v)



**Voltage Multiplier**  
2005



**Blower & Motor**  
4007

# INSTALLATION INSTRUCTIONS

Follow diagram that relates

## Figure 1 I-BEAM SUPPORT INSTALLATION

**IMPORTANT THIS UNIT MUST BE ATTACHED TO THE BUILDING STRUCTURE FOR SUPPORT.**

*Unit is heavy and awkward, please use two persons to lift unit and properly install.*

**PLEASE FOLLOW EXAMPLES FOR PROPER INSTALLATION.**

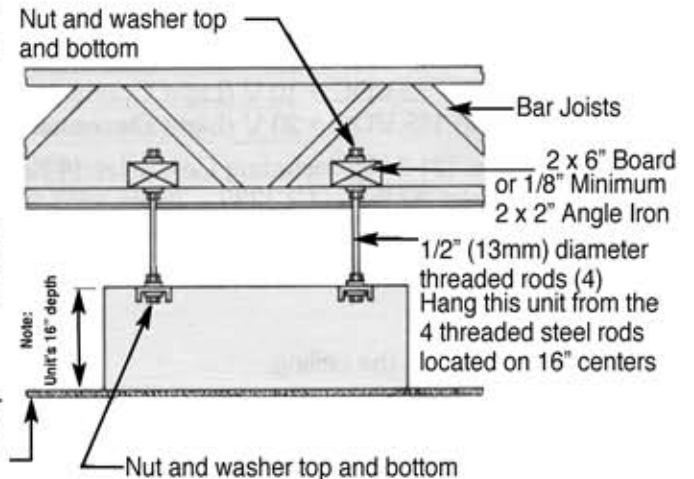

Suspended (false) ceiling

**NOTE: To meet Underwriter's Laboratories requirements, this unit must be hard wired.**

## Figure 2 CONCRETE CEILING INSTALLATION

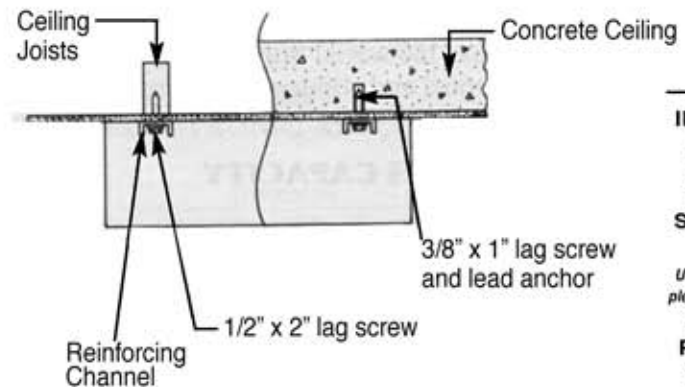

**IMPORTANT THIS UNIT MUST BE ATTACHED TO THE BUILDING STRUCTURE FOR SUPPORT.**

*Unit is heavy and awkward, please use two persons to lift unit and properly install.*

**PLEASE FOLLOW EXAMPLES FOR PROPER INSTALLATION.**

The above system, HealthWay 1220-DFS is best mounted in the center of the room so contaminated air can be drawn into the bottom of the unit and fresh clean air discharged evenly from the sides or from the multiple duct system.

**NOTE: For easier installation and to avoid dropping of the unit, please use two person's to install this unit.**



9. Lift front of unit from table and connect to the two hinges on the housing of the unit that is already in ceiling. Unit is heavy so hold securely while performing the following task.



10. Plug power cord into receptacle that is located in the upper right hand corner of the units housing.



11. Connect the two slide hanger supports located on each side of the component section in the housing. Turn cap screws to secure (hand tight only).



12. Lift Component Section up into Upper Housing and line up the two thumb screws.



13. Fasten the two thumb screws tightly.



14. HealthWay 1220 Ceiling Unit completely installed.

Figure 3

### Field Wiring HealthWay Ceiling Model 1220 DFS

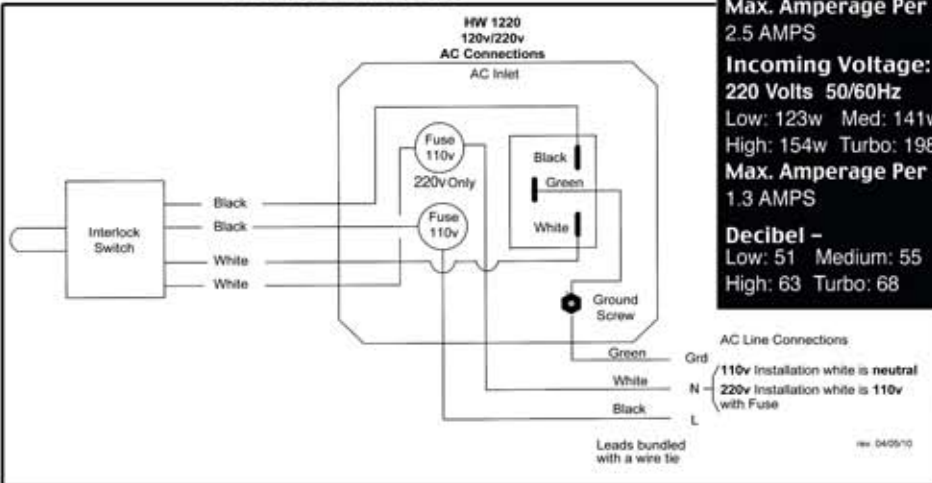

**Incoming Voltage:**  
110/120 Volts 60 Hz  
Low: 125w Med: 180w  
High: 210w Turbo: 300w  
**Max. Amperage Per Unit:**  
2.5 AMPS

**Incoming Voltage:**  
220 Volts 50/60Hz  
Low: 123w Med: 141w  
High: 154w Turbo: 198w  
**Max. Amperage Per Unit:**  
1.3 AMPS

**Decibel -**  
Low: 51 Medium: 55  
High: 63 Turbo: 68

**NOTE: THE UNIT MUST BE HARD WIRED WHEN RECESS MOUNTED TO MEET UNDERWRITERS LABORATORIES or CE SPECIFICATIONS.**

## Filter Installation Instructions



### To Access Filters

- Turn off unit
  - Wait for motor to quit spinning
- Unscrew two screws holding Filter Access Panel shut

To install filters, turn the air purifier off and wait for motor to quit spinning. Unscrew 2 screws on the Filter Access Panel and then lower panel door. Note: Remove plastic covering on filters before inserting filters.



### CAUTION NOTICE!

To prevent injury, please wait for motor to stop spinning before changing filters or before taking unit out of the ceiling.

When changing filters, start at the top and remove each filter (3 filters and 1 grid) accordingly: DFS Filter, DFS Grid, Carbon Filter, and Pre-filter. Replace necessary filter and put filters back in order. Follow label instructions and arrows on each filter. The Pre-filter is directly under the Filter Access Panel.

## Changing the PCO Bulb



Hold firmly onto the end of the bulb, (DO NOT HOLD ONTO BULB) and pull out slowly, unplugging male end or connector from the female end.



Insert new bulb again hold firmly, but DO NOT HOLD ONTO BULB. Connect the male end into the female end.



Photo of PCO Bulb in place.